

Shaft Bearing Press Operation Manual

Model: Team 512 Shaft Bearing Press

Version: 1.0

Date of Publication: 3-29-2024

Project Overview

The Objective of this project is to redesign the existing bearing press to press bearings of various sizes onto shafts while ensuring ease of manipulation and user safety.

1. Introduction

The Team 512 Shaft Bearing Press is designed for efficient installation of bearings onto shafts using two types of shafts. This manual provides instructions for safe and effective operation of the press.

2. Safety Precautions

- Always wear appropriate personal protective equipment (PPE), including safety goggles and gloves, when operating the press.
- Keep hands clear of moving parts and pinching points during operation.
- Do not engage in press operation if the guard door is open or if any safety features are compromised.
- Ensure the work area is clear of debris and obstructions before operating the press.
- Only trained personnel should operate the press. Keep unauthorized personnel away from the equipment.

3. Component Descriptions

1. **Pneumatic Actuator:** This device converts energy in the form of compressed air and uses it to apply pressure into mechanical motion. For purposes here, the mechanical motion is pushed down towards a baseplate with a shaft to be placed in a bearing. The actuator is comprised of a long aluminum tube that houses the internals that react to the pneumatic pressure and push down a steel rod that can hold any screwable component. Around the large tube are small black rods used to hold the actuator in place on a plate placed on top of the press.



Fig.1: Pneumatic Actuator

2. **Chuck:** This device holds the selected shaft in place while the pneumatic actuator is applying pressure to the bearing. The shaft should be placed in the chuck before operation. The piece is primarily made of steel and has small holes for the placement of magnets. These magnets hold the shaft in place to prevent it from falling off the chuck before, during, and after operation.

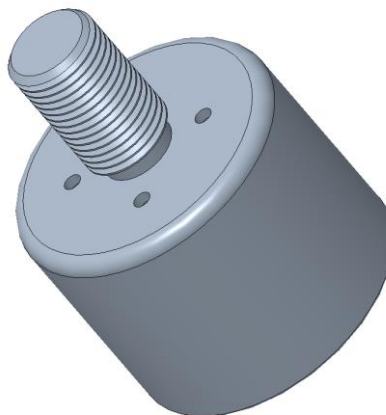

Fig.2: Chuck

3. **Press Shafts:** These pieces are pressed downward towards the bearing during operation. The shafts can be removed and swapped out for different ones depending on the bearing and height of the shaft. These parts are machined from steel and polished finely.

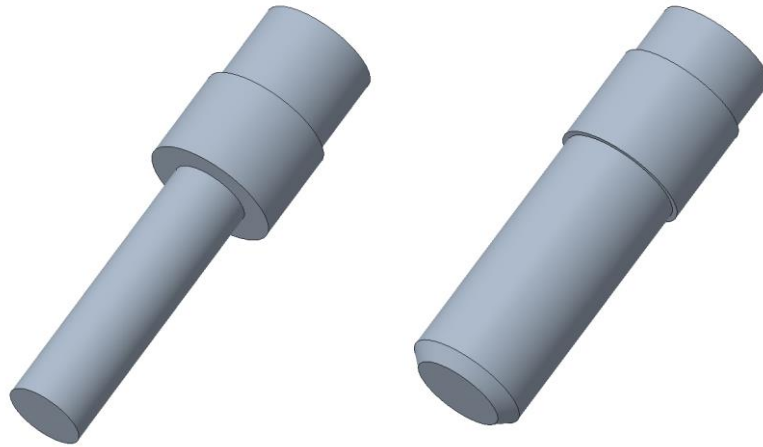

Fig.3: New and Old Shafts (Non-NDA Versions)

4. **Bearing Housing:** This component houses the bearing when it's placed in the press after being heated in the oven.
5. **Base Plate:** This part is used to hold the bearing and its housing in place for use in the press. The plate has a large hole in its center that indents downward into it. The plate also has small threaded screw holes on the bottom side of it so that two small rectangular steel plates can be screwed on to it for proper placement on the press. Both small plates have two holes at the bottom that face the side of the press. These holes are non-threaded and used to hold screws placed through them and threaded onto holes on the side plates of the press. This holds down the base plate and aligns it for operation.

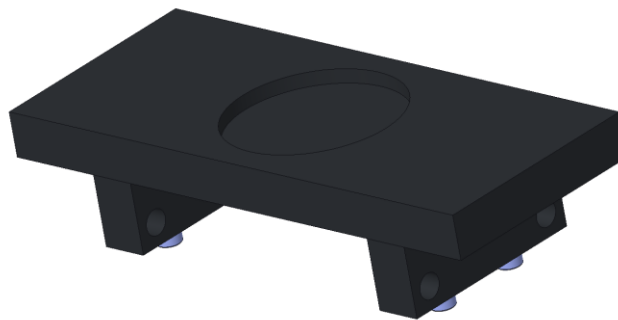

Fig.4: Base Plate

6. **3/8-24 x 2 1/4" LONG SHCS Screws:** Screws used to hold the small rectangular plates on to the larger baseplate. These are placed through the holes at the bottom of the smaller plates and then screwed through the bottom of the larger base plate.

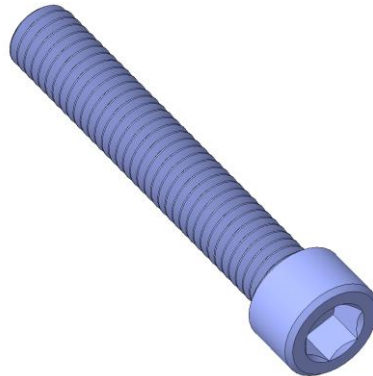

Fig. 5: 3/8-24 x 2 1/4" LONG SHCS Screw

7. **1/2-20 x 1 3/4" LONG SHCS Screws:** Screws used to hold the entire base plate onto the inside part of the side plates of the press. These are placed through the non-threaded holes of the smaller plates on the side and threaded through holes on the side of the side plates.



Fig. 6: 1/2-20 x 1 3/4" LONG SHCS Screw

8. **Side Plate:** The press is composed of two black oxide coated steel plates. These parts hold up the press and have a variety of holes, both threaded and non-threaded, that are used in the operation of the press. The plates also have 4 slots at its top inside area that is used to hold up the top plate, which in turn holds up the actuator. The top plate is held between the two side plates by pressure and a key on both sides placed between the slot on the side plate and a slot on the top plate.



Fig.7: Side plate inside and outside view

9. **Top Plate:** This part holds the pneumatic actuator on top of itself and is placed at the top of the press. The plate is held in by keys placed between the side plates and the top plate using keys in the slots between them to level itself. The plate also has 4 threaded holes for 3/8-24 x 7/8" LONG SHCS screws, this applies more pressure to hold both itself and the actuator up.



Fig.8: Top Plate

10. **Side Plate Key:** This component is used to hold and level the top plate between the two side plates of the press. This is a small rectangular piece primarily composed of steel.

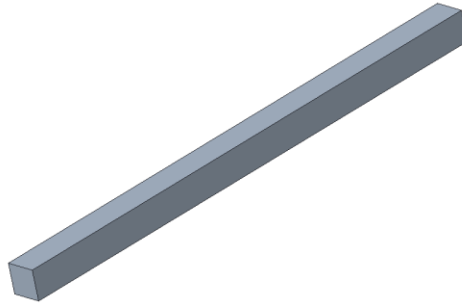

Fig.9: Side Plate Key

11. **3/8-24 x 7/8" LONG SHCS Screws:** Screws that are used to hold the top plate between the two side plates of the press.



Fig.10: 3/8-24 x 7/8" LONG SHCS Screw

12. **Tie Bar:** This part is used to hold the side plates together by pressure. The steel bar is placed between both side plates at the top and the bottom of the press in non-threaded holes. To create the pressure that holds them together, the bars have threaded ends that nuts are placed on the outside part of the press.

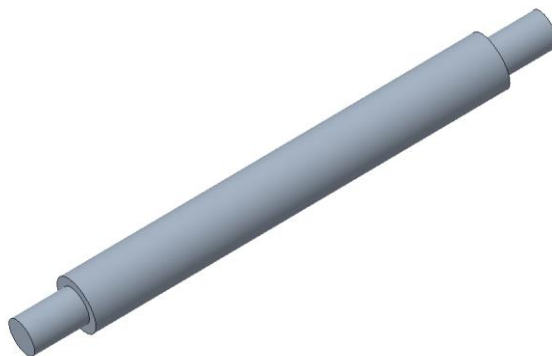

Fig.11: Tie Bar

13. **Tie Bar Nut:** This is the nut that holds both the tie bars in place and is at the end of each side of the tie bar.

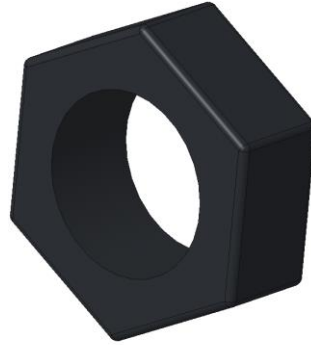

Fig.12: Tie Bar Nut

14. **Angled Foot Mount:** This piece of black oxide steel is used to hold the press on the table it's placed on. The part is bent at a 90-degree angle and has two holes on the upright side and three holes on the flat horizontal side. All holes are non-threaded. Two screws are placed on each side, the upright side is screwed into threaded holes on the side plates of the press. Two more screws are threaded on the flat horizontal side onto the table to secure the press in place for operation.



Fig.13: Angled Foot Mount

15. **5/8-18 x 1" LONG SHCS Screws:** Screws used to hold the angled foot mount and the side plates of the press together. These screws are placed through the non-threaded hole

on the upright side of the foot mount and then threaded through the holes on both side plates.

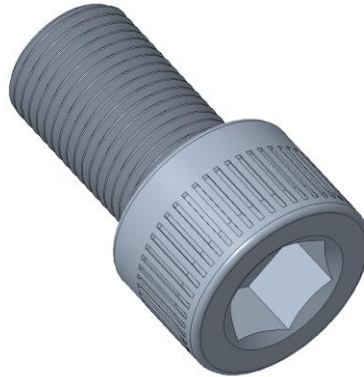

Fig.14: 5/8-18 x 1" LONG SHCS Screw

16. **Cage:** This is placed around the area of the press and is to protect the user from any potential incidents that could occur during operation. The structure is composed of steel and has a wire mesh pattern around the outside, with steel bars holding it together. The pneumatic lock is placed on the outside of the frame so that when it's in operation, the cage door will not be able to open. The cage is held in place by several screws that are placed through small holes in the cage and threaded into the table.

17. **Two Hand Control Unit:** This component is used to control the press during operation. There are two buttons on each side of the controller, to activate the press the door must be closed for the pneumatic lock and both buttons must be pushed at the same time. To stop applying pressure release both buttons.



Fig.15: Two Hand Control Unit

4. Operating Instructions

- **Prepare the Press:** Ensure the press is securely anchored to the work surface.
- **Open Guard Door:** Open guard door and prepare press surface for shaft and bearing.

- **Select Shaft Type:** Identify the appropriate shaft type for the bearing installation.
- **Insert Shaft:** Place the chosen shaft into the chuck of the press. The chuck should magnetically hold the shaft in place.
- **Heat Bearing:** Preheat the oven to 605°F (320°C) and place the bearing sleeve and radial sensor inside the oven for a minimum of 30 minutes.
- **Place Bearing:** Using a thermal protection glove, remove the radial sensor bearing from the oven and place it in the inset on the base plate of the press.
- **Close Guard Door:** Once the bearing is in place, close the guard door securely.
- **Activate Press:** Simultaneously press and hold both actuator buttons of the two-hand control mechanism until the bearing is fully pressed onto the shaft. Continue holding until ready.
- **Release Pressure:** Release pressure from the press by removing your hands from the two-hand control mechanism. The shaft will retract back.
- **Complete Installation:** Verify that the bearing is securely installed onto the shaft.
- **Shutdown:** Turn off the press and ensure all components are in their proper positions for storage.

5. Maintenance

- Regularly inspect the press for signs of wear, damage, or malfunction. Address any issues promptly.
- Keep the press clean and free of debris.
- Lubricate moving parts as recommended by the manufacturer.
- Follow any additional maintenance procedures outlined in the press manual.

6. Troubleshooting

- If the press fails to activate, check for proper alignment of the shaft and bearing.
- If the bearing does not press fully onto the shaft, ensure the bearing and shaft are compatible and properly aligned.
- If the guard door fails to close securely, inspect for obstructions or damage to the door mechanism.

7. Emergency Procedures

- In case of emergency, immediately release pressure from the press by removing hands from the two-hand control mechanism.
- Shut down the press and follow emergency procedures as outlined in your facility's safety protocols.

8. Warranty and Support

For warranty information and technical support, contact Kevin Lohman or refer to the press documentation provided.

9. Conclusion

The Team 512 Shaft Bearing Press is a valuable tool for efficient bearing installation. By following the instructions in this manual and adhering to safety precautions, you can ensure safe and effective operation of the press.

